

**PUSH-PULL FOUR CHANNEL DRIVERS**

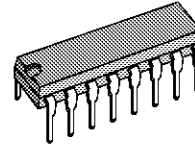
- OUTPUT CURRENT 1A PER CHANNEL
- PEAK OUTPUT CURRENT 2A PER CHANNEL (non repetitive)
- INHIBIT FACILITY
- HIGH NOISE IMMUNITY
- SEPARATE LOGIC SUPPLY
- OVERTEMPERATURE PROTECTION

**DESCRIPTION**

The L293B and L293E are quad push-pull drivers capable of delivering output currents to 1A per channel. Each channel is controlled by a TTL-compatible logic input and each pair of drivers (a full bridge) is equipped with an inhibit input which turns off all four transistors. A separate supply input is provided for the logic so that it may be run off a lower voltage to reduce dissipation.

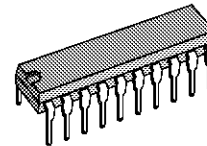
Additionally, the L293E has external connection of sensing resistors, for switchmode control.

The L293B and L293E are package in 16 and 20-pin plastic DIPs respectively ; both use the four center pins to conduct heat to the printed circuit board.



DIP16

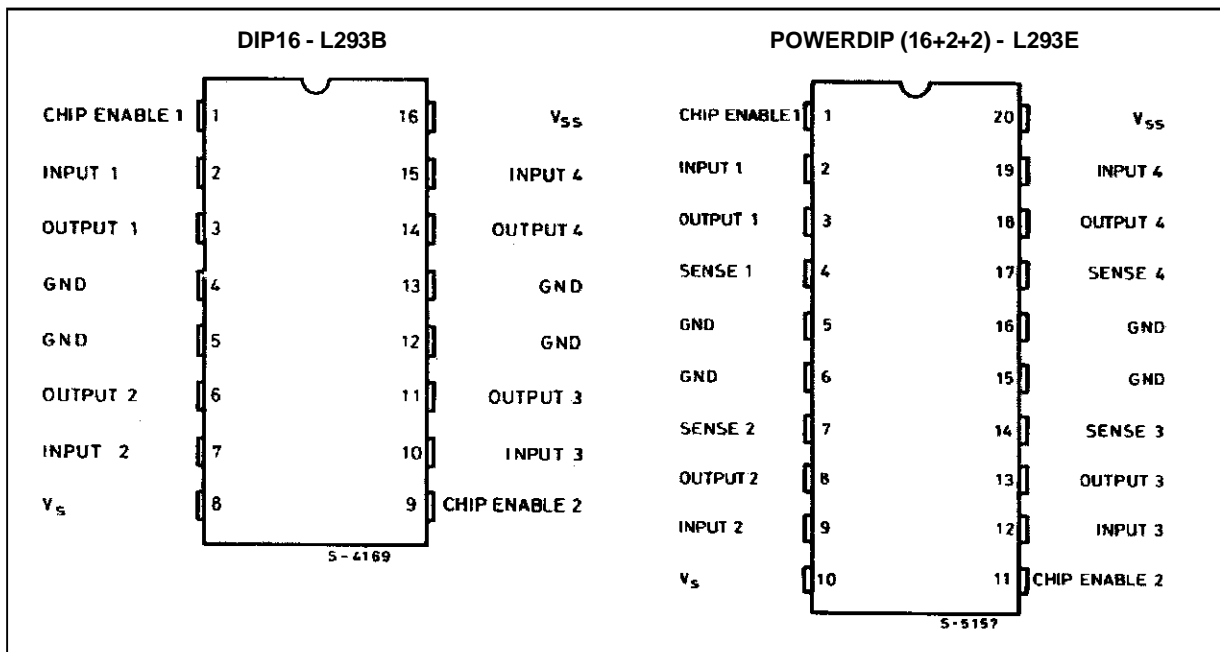
ORDERING NUMBER : L293B



POWERDIP (16 + 2 + 2)

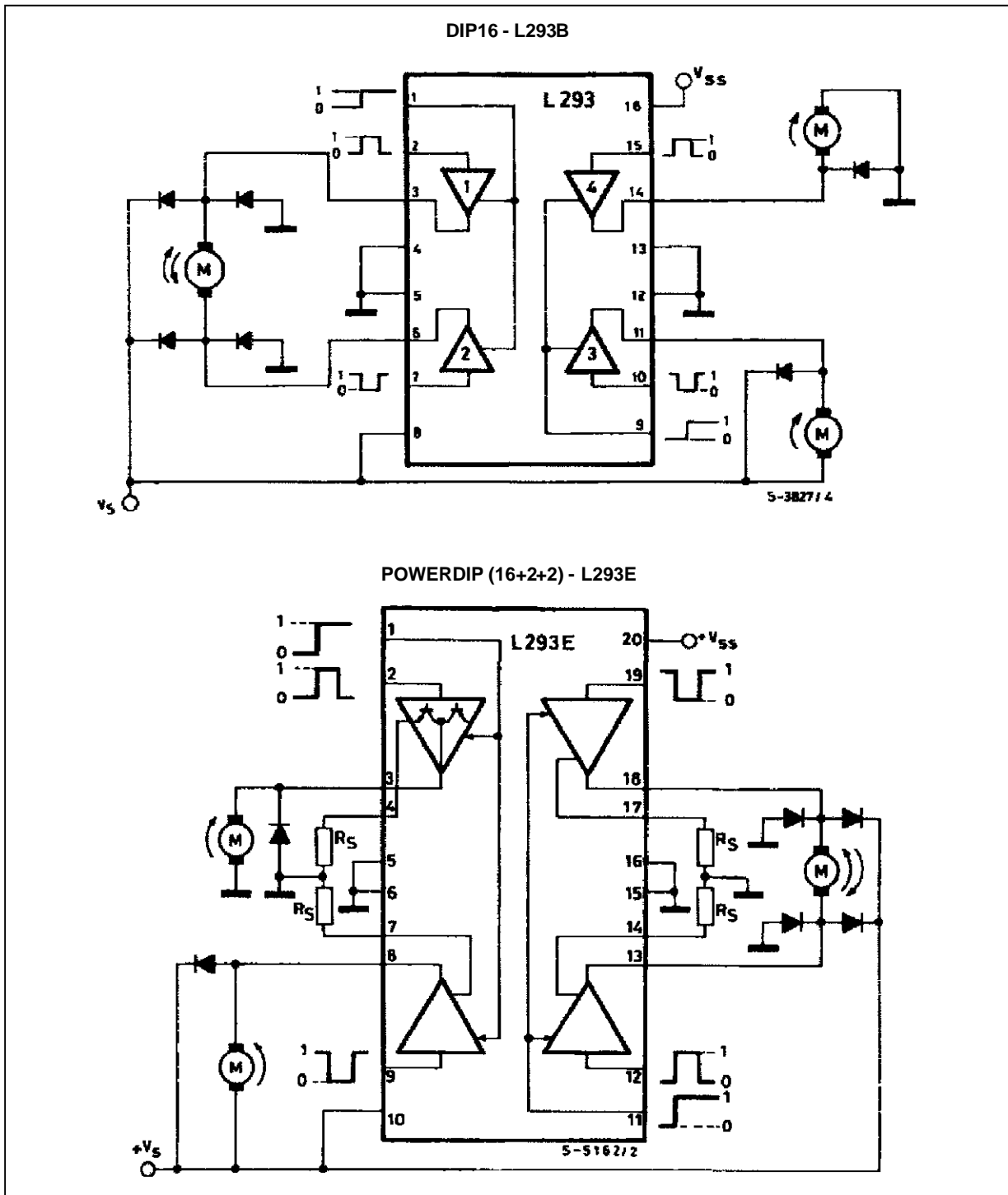
ORDERING NUMBER : L293E

**PIN CONNECTIONS**



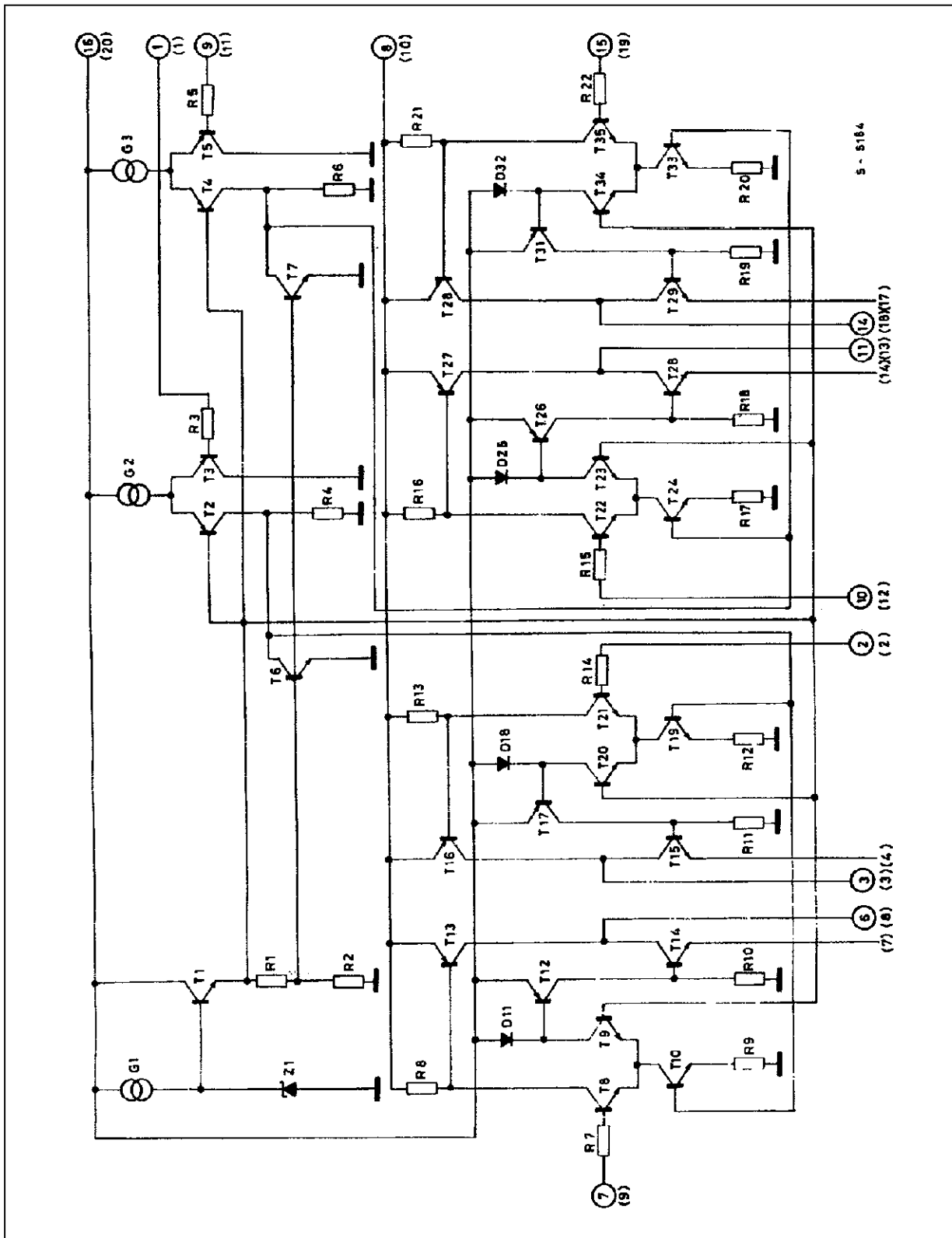
L293B - L293E

BLOCK DIAGRAMS



L293B - L293E

SCHEMATIC DIAGRAM



(\*) In the L293 these points are not externally available. They are internally connected to the ground (substrate).  
 O Pins of L293                      () Pins of L293E.

## L293B - L293E

### ABSOLUTE MAXIMUM RATINGS

Symbol	Parameter	Value	Unit
$V_s$	Supply Voltage	36	V
$V_{ss}$	Logic Supply Voltage	36	V
$V_i$	Input Voltage	7	V
$V_{inh}$	Inhibit Voltage	7	V
$I_{out}$	Peak Output Current (non repetitive t = 5ms)	2	A
$P_{tot}$	Total Power Dissipation at $T_{ground-pins} = 80^{\circ}C$	5	W
$T_{stg}, T_j$	Storage and Junction Temperature	-40 to +150	$^{\circ}C$

### THERMAL DATA

Symbol	Parameter	Value	Unit
$R_{th\ j-case}$	Thermal Resistance Junction-case	Max. 14	$^{\circ}C/W$
$R_{th\ j-amb}$	Thermal Resistance Junction-ambient	Max. 80	$^{\circ}C/W$

### ELECTRICAL CHARACTERISTICS

For each channel,  $V_s = 24V$ ,  $V_{ss} = 5V$ ,  $T_{amb} = 25^{\circ}C$ , unless otherwise specified

Symbol	Parameter	Test Conditions	Min.	TYp.	Max.	Unit
$V_s$	Supply Voltage		$V_{ss}$		36	V
$V_{ss}$	Logic Supply Voltage		4.5		36	V
$I_s$	Total Quiescent Supply Current	$V_i = L \quad I_o = 0 \quad V_{inh} = H$ $V_i = H \quad I_o = 0 \quad V_{inh} = H$ $V_i = H \quad I_o = 0 \quad V_{inh} = L$		2 16	6 24 4	mA
$I_{ss}$	Total Quiescent Logic Supply Current	$V_i = L \quad I_o = 0 \quad V_{inh} = H$ $V_i = H \quad I_o = 0 \quad V_{inh} = H$ $V_i = H \quad I_o = 0 \quad V_{inh} = L$		44 16 16	60 22 24	mA
$V_{iL}$	Input Low Voltage		-0.3		1.5	V
$V_{iH}$	Input High Voltage	$V_{ss} \leq 7V$ $V_{ss} > 7V$	2.3 2.3		$V_{ss}$ 7	V
$I_{iL}$	Low Voltage Input Current	$V_{iL} = 1.5V$			-10	$\mu A$
$I_{iH}$	High Voltage Input Current	$2.3V \leq V_{iH} \leq V_{ss} - 0.6V$		30	100	$\mu A$
$V_{inhL}$	Inhibit Low Voltage		-0.3		1.5	V
$V_{inhH}$	Inhibit High Voltage	$V_{ss} \leq 7V$ $V_{ss} > 7V$	2.3 2.3		$V_{ss}$ 7	V
$I_{inhL}$	Low Voltage Inhibit Current	$V_{inhL} = 1.5V$		-30	-100	$\mu A$
$I_{inhH}$	High Voltage Inhibit Current	$2.3V \leq V_{inhH} \leq V_{ss} - 0.6V$			$\pm 10$	$\mu A$
$V_{CEsatH}$	Source Output Saturation Voltage	$I_o = -1A$		1.4	1.8	V
$V_{CEsatL}$	Sink Output Saturation Voltage	$I_o = 1A$		1.2	1.8	V
$V_{SENS}$	Sensing Voltage (pins 4, 7, 14, 17) (**)				2	V
$t_r$	Rise Time	$0.1$ to $0.9 V_o$ (*)		250		ns
$t_f$	Fall Time	$0.9$ to $0.1 V_o$ (*)		250		ns
$t_{on}$	Turn-on Delay	$0.5 V_i$ to $0.5 V_o$ (*)		750		ns
$t_{off}$	Turn-off Delay	$0.5 V_i$ to $0.5 V_o$ (*)		200		ns

\* See figure 1

\*\* Referred to L293E

### TRUTH TABLE

$V_i$ (each channel)	$V_o$	$V_{inh}^{(\infty)}$
H	H	H
L	L	H
H	X <sup>(*)</sup>	L
L	X <sup>(*)</sup>	L

(\*) High output impedance

(\*\*) Relative to the considerate channel

L293B - L293E

Figure 1 : Switching Timers

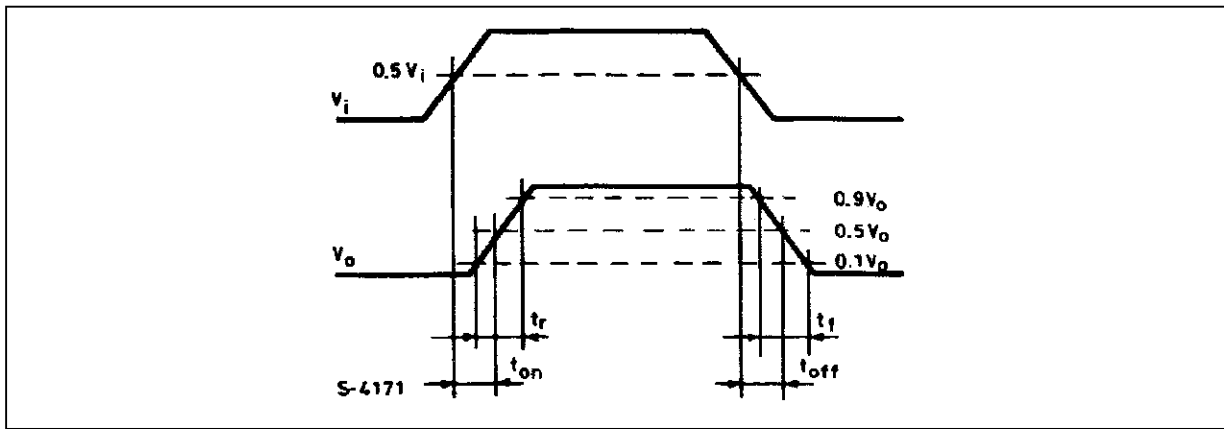


Figure 2 : Saturation voltage versus Output Current

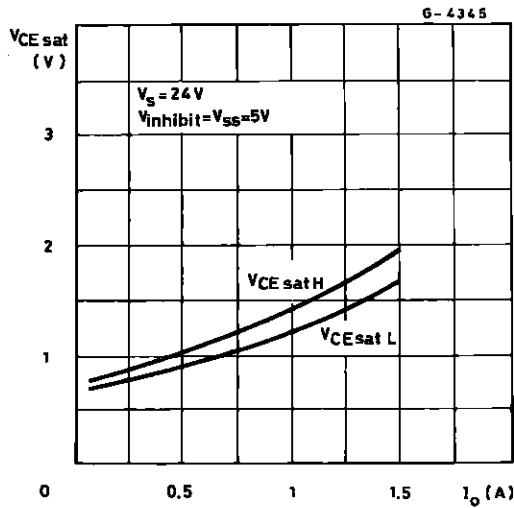


Figure 4 : Sink Saturation Voltage versus Ambient Temperature

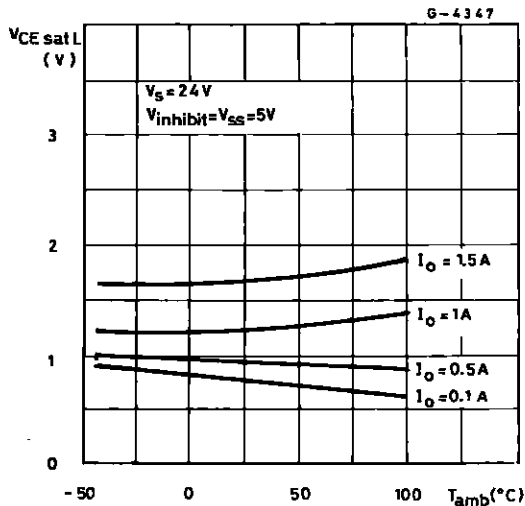


Figure 3 : Source Saturation Voltage versus Ambient Temperature

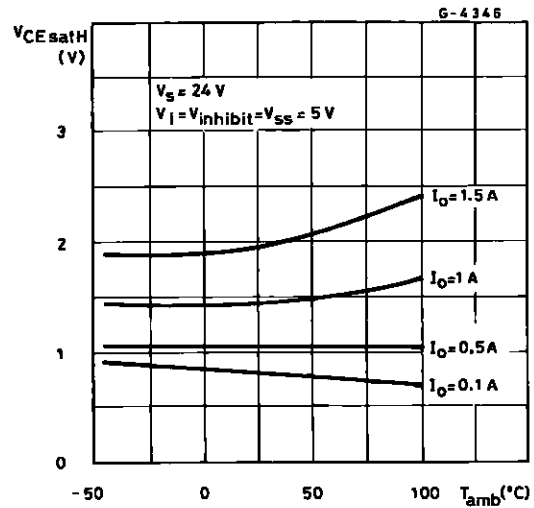
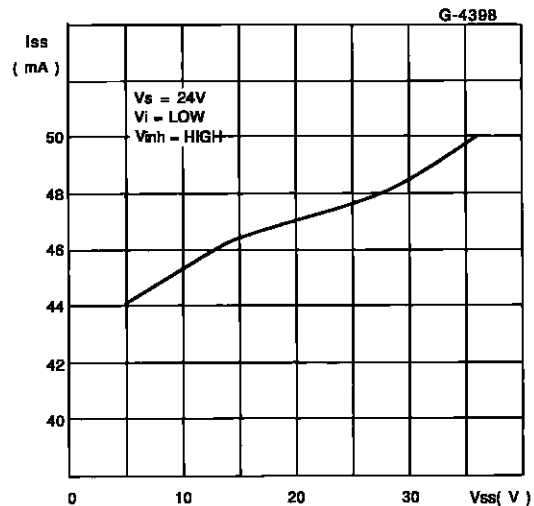
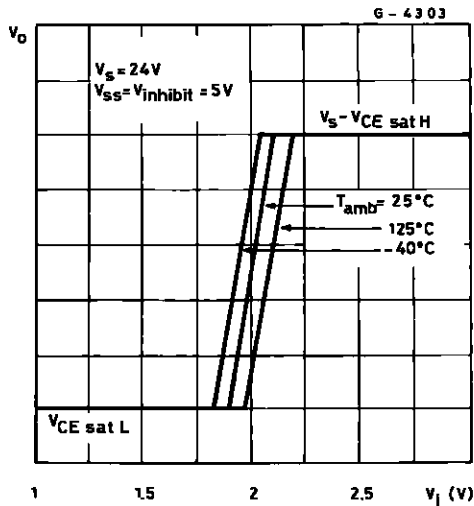


Figure 5 : Quiescent Logic Supply Current versus Logic Supply Voltage

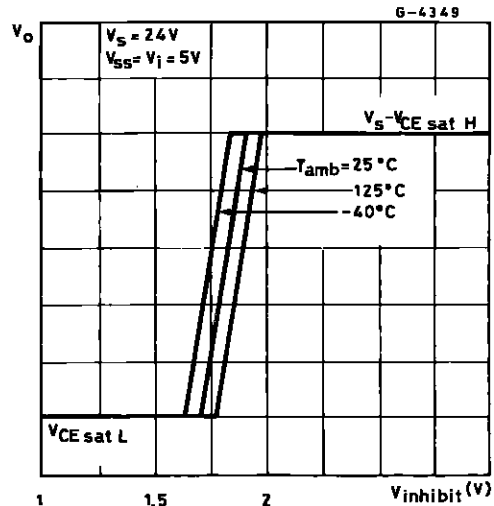


**L293B - L293E**

**Figure 6 :** Output Voltage versus Input Voltage

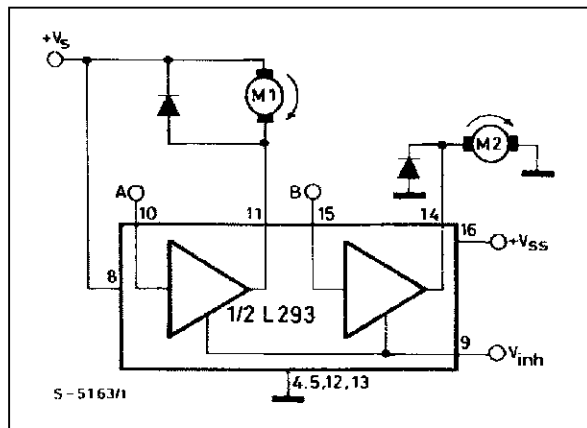


**Figure 7 :** Output Voltage versus Inhibit Voltage



**APPLICATION INFORMATION**

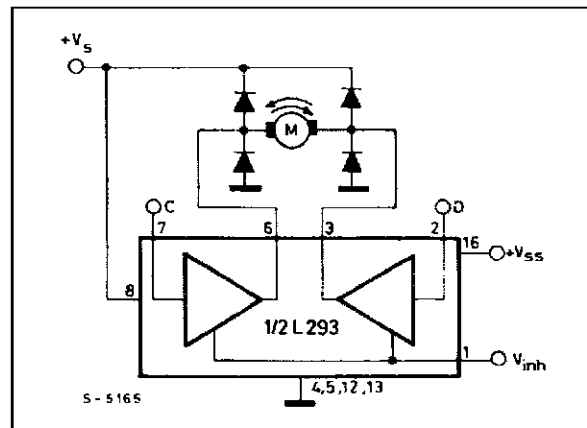
**Figure 8 :** DC Motor Controls (with connection to ground and to the supply voltage)



$V_{inh}$	A	M1	B	M2
H	H	Fast Motor Stop	H	Run
H	L	Run	L	Fast Motor Stop
L	X	Free Running Motor Stop	X	Free Running Motor Stop

L = Low      H = High      X = Don't Care

**Figure 9 :** Bidirectional DC Motor Control

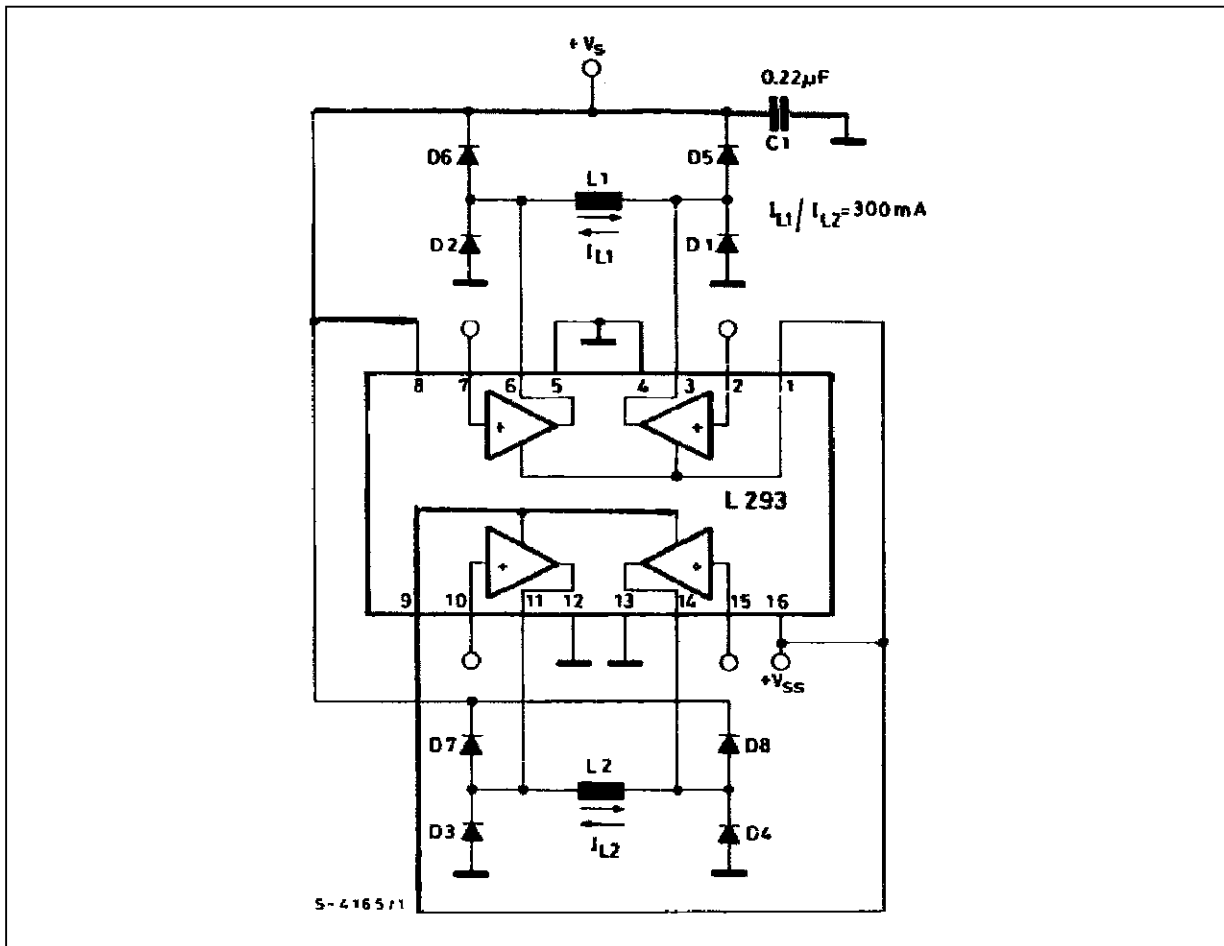


Inputs	Function	
$V_{inh} = H$	C = H ; D = L	Turn Right
	C = L ; D = H	Turn Left
	C = D	Fast Motor Stop
$V_{inh} = L$	C = X ; D = X	Free Running Motor Stop

L = Low      H = High      X = Don't Care

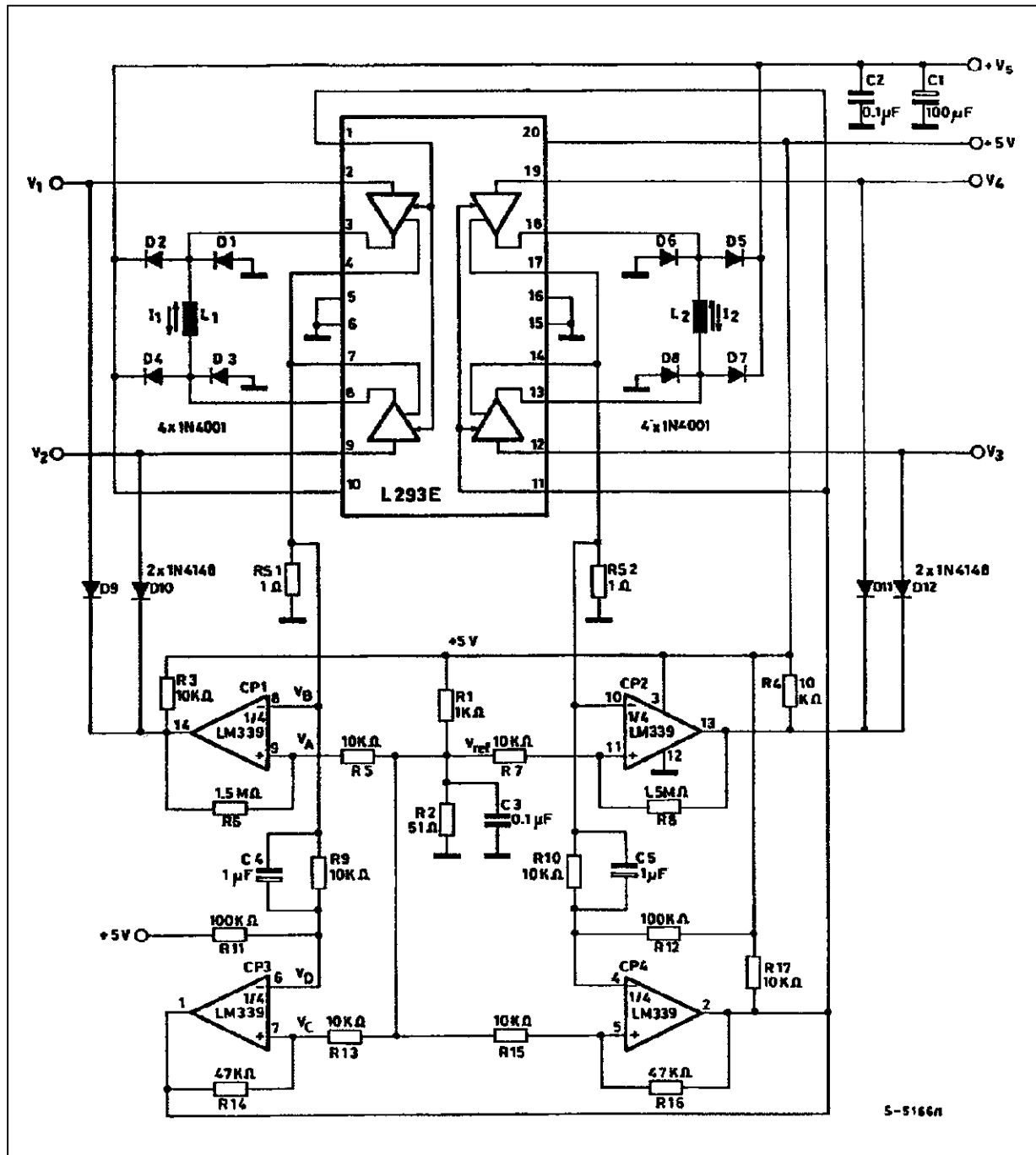
L293B - L293E

Figure 10 :Bipolar Stepping Motor Control



L293B - L293E

Figure 11 :Stepping Motor Driver with Phase Current Control and Short Circuit Protection



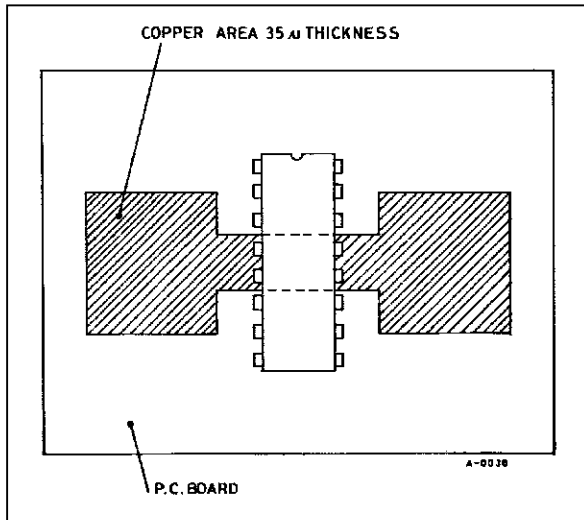


## L293B - L293E

### MOUNTING INSTRUCTIONS

The  $R_{th\ j-amb}$  of the L293B and the L293E can be reduced by soldering the GND pins to a suitable copper area of the printed circuit board as shown in figure 12 or to an external heatsink (figure 13).

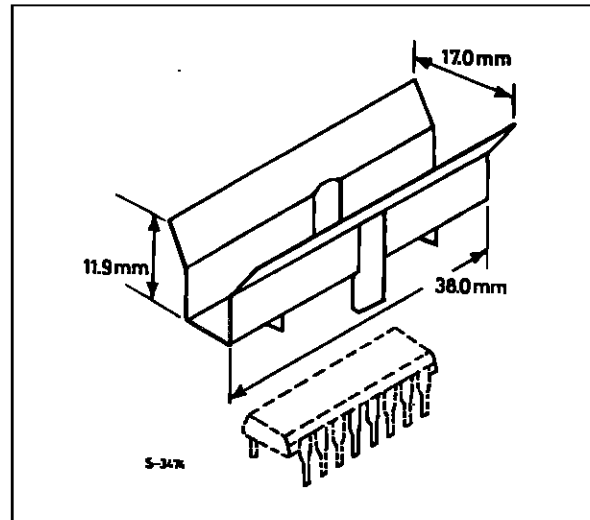
**Figure 12** :Example of P.C. Board Copper Area which is Used as Heatsink



During soldering the pins temperature must not exceed 260°C and the soldering time must not be longer than 12 seconds.

The external heatsink or printed circuit copper area must be connected to electrical ground.

**Figure 13** :External Heatsink Mounting Example ( $R_{th} = 30^{\circ}\text{C/W}$ )

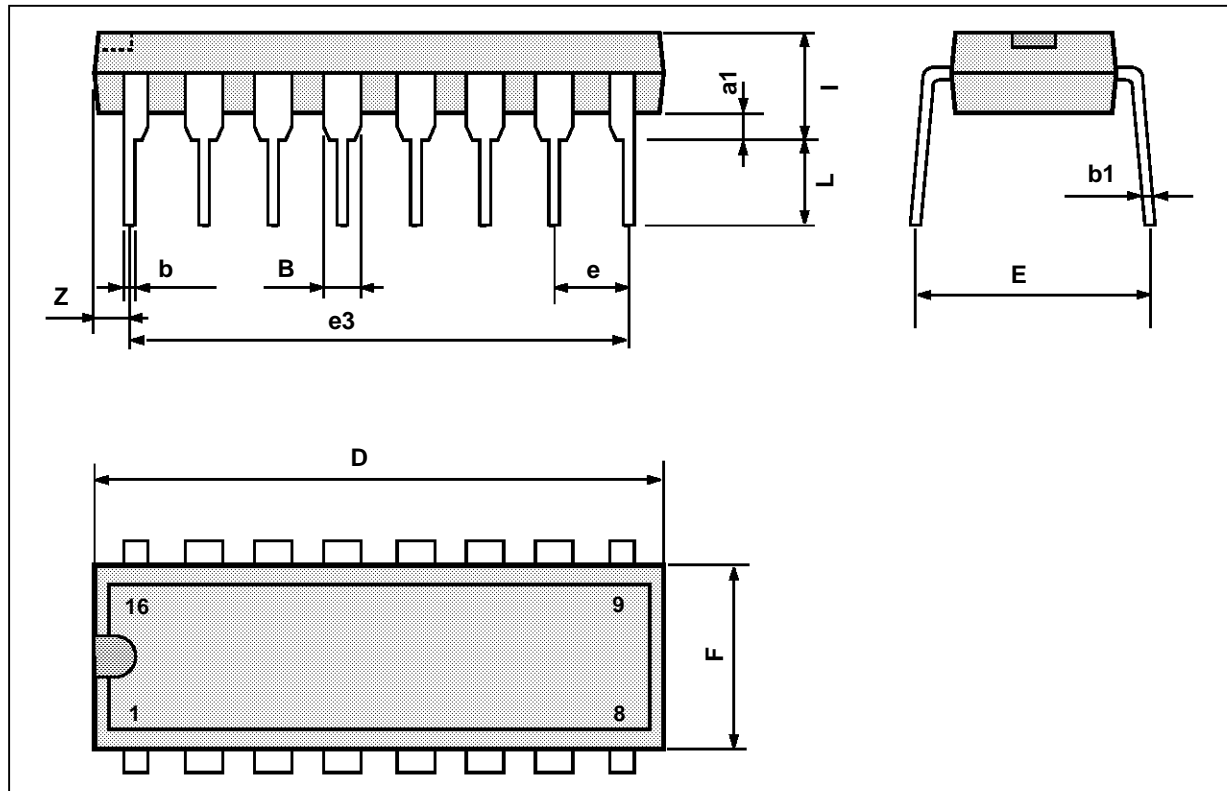


L293B - L293E

DIP16 PACKAGE MECHANICAL DATA

Dimensions	Millimeters			Inches		
	Min.	Typ.	Max.	Min.	Typ.	Max.
a1	0.51			0.020		
B	0.77		1.65	0.030		0.065
b		0.5			0.020	
b1		0.25			0.010	
D			20			0.787
E		8.5			0.335	
e		2.54			0.100	
e3		17.78			0.700	
F			7.1			0.280
i			5.1			0.201
L		3.3			0.130	
Z			1.27			0.050

DIP16PW:TBL



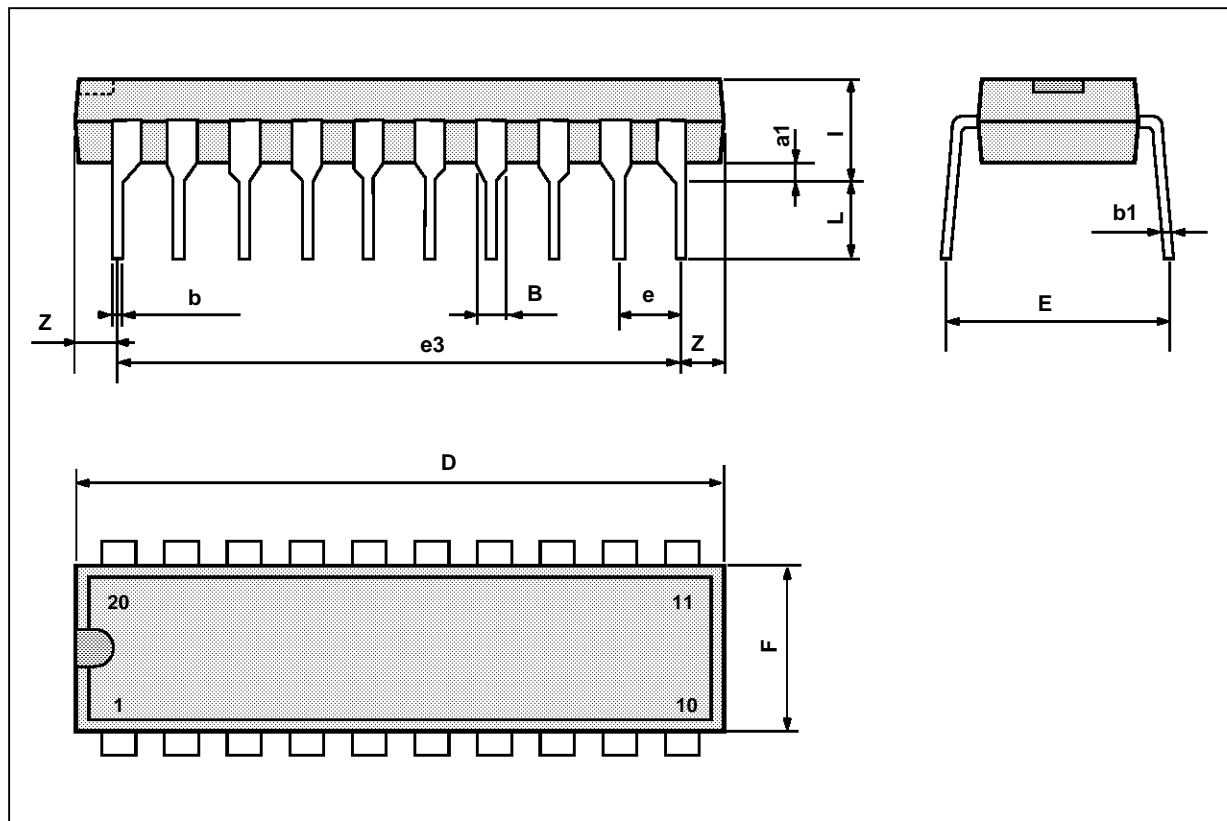
PMDIP16W/EPS

**L293B - L293E**

**POWERDIP (16+2+2) PACKAGE MECHANICAL DATA**

Dimensions	Millimeters			Inches		
	Min.	Typ.	Max.	Min.	Typ.	Max.
a1	0.51			0.020		
B	0.85		1.4	0.033		0.055
b		0.5			0.020	
b1	0.38		0.5	0.015		0.020
D			24.8			0.976
E		8.8			0.346	
e		2.54			0.100	
e3		22.86			0.900	
F			7.1			0.280
i			5.1			0.201
L		3.3			0.130	
Z			1.27			0.050

DIP20PW.TBL



PMDIP20WEPS