

White LED Step-up Converter

Features

- I **Matched LED Current with Overvoltage Protection**
- I **Drives up to 4 LEDs in series**
- I **Up to 85% Efficiency**
- I **Over 80mA Output Current Capacity**
- I **Low 400mV Feedback Reference,**
- I **Internal Current Limit 400mA**
- I **Under Voltage Lock Out Circuits**
- I **0.1µA Low Shutdown Supply Current**
- I **SOT-23-6 Packages**
- I **RoHS Compliant and 100% Lead (Pb)-Free and Green (Halogen Free with Commercial Standard)**

General Description

The AP8807 is step-up DC/DC converter that drives white LED with a constant current. The device can driver up to 4 series white LEDs from a single-cell Li-Ion battery. Series connection of the LEDs provides constant LED current that results in uniform brightness.

The AP8807 features a minimum off-time current-limited PFM control scheme, which combines the advantages of PWM (higher output power and efficiency) and those of traditional PFM (low quiescent current). The LED current is set with an external sense resistor (R_s) and is regulated by the feedback pin (FB) that regulates the voltage across the sense resistor to 400mV (Typ). The low 400mV feedback reference voltage reduces power loss and improves efficiency for white LED driver applications.

Output overvoltage protection (OVP) is integrated to prevent damage in case of output open circuit condition (e.g. faulty LED). The OVP pin can monitor the output voltage and turn off the converter in the event of overvoltage condition. The AP8807 is avail- able in SOT-23-6 packages.

Applications

- I Cellular Phone
- I Digital Still and Video Camera
- I PDA, Packet PC, Smart Phone
- I Small LCD Display
- I Handheld Computers and Devices

Typical Application Circuit

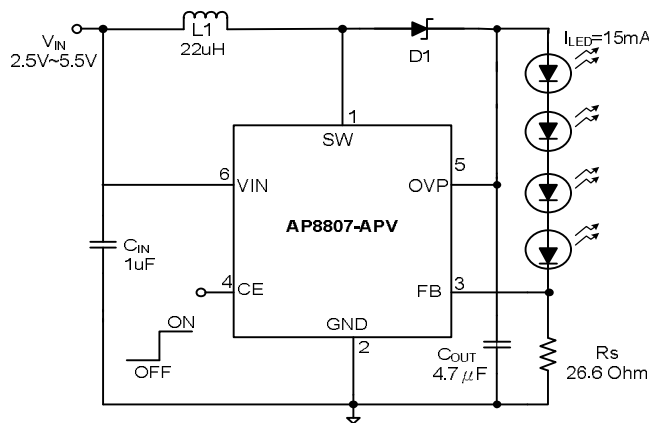

Figure 1. AP8807 Typical Application for driving 4 White LEDs

Ordering Information

| | |
|--|--|
| <p>AP8807 — </p> <p>Package Code Lead Free Code Feedback Reference Voltage</p> | <p>Feedback Reference Voltage :</p> <p>A : 400mV</p> <p>Lead Free Code :</p> <p>P : Commercial Standard, Lead (Pb) Free And Phosphorous (P) Free Package</p> <p>G : Green (Halogen Free with Commercial Standard)</p> <p>Package Code :</p> <p>V : SOT-23-6</p> |
|--|--|

Pin Description

| <p>(Top View)</p> <p>SOT-23-6</p> | Pin | Pin Name | Description |
|-----------------------------------|-----|-----------------|---|
| | 1 | SW | Switch pin. Connect inductor/diode here. Minimize trace area at this pin to reduce EMI. |
| | 2 | GND | Ground pin. Connect to local ground plane. |
| | 3 | FB | Feedback pin. Reference voltage is 400mV (AP8807-A). Connect cathode of lowest LED and current sense resistor here. |
| | 4 | CE | Chip enable pin. Tie CE pin to 1.5V or higher to enable device; 0.4V or less to shutdown the device. Do not float this pin. |
| | 5 | OVP | Overshoot protection. Connect this pin to the output capacitor of the converter. |
| | 6 | V _{IN} | Input supply pin. Must be locally bypassed. |

Package Marking Information

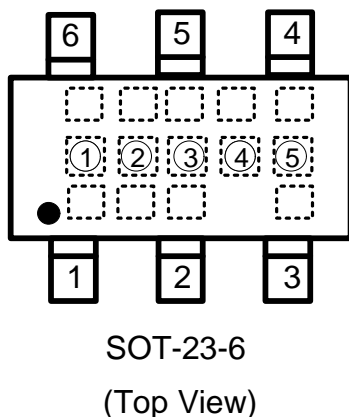

Top Point Represents Products Series

| Mark | Products Series |
|---------------|--|
| Top Point Dot | Dot above Product Code : Lot Code (see note*1) |

Middle Represents Products Series

| | Mark | Description |
|----|---------|--|
| ① | 07 | AP8807 |
| ②③ | Voltage | Feedback Reference Voltage: AA |
| ④ | V | Package Code |
| ⑤ | Dot, G | Dot for Pb-free package G for Green package |

Bottom Point Represents Production Date Code

| Mark | Products Series |
|--------------|--|
| Bottom Dot | Dot under Product Code : Year Code (see note*2) |
| The last Dot | Week Code : i.1-26 week : A~Z ii.27-52 week : <u>A</u> ~ <u>Z</u> (add underscore) |

Note :

Lot Code :

| Lot | Code | | | | |
|-----|------|---|---|---|---|
| 1 | | | | | • |
| 2 | | | | • | |
| 3 | | | | • | • |
| 4 | | | • | | |
| 5 | | | • | | • |
| 6 | | | • | • | |
| 7 | | | • | • | • |
| 8 | | • | | | |
| 9 | | • | | | • |
| 10 | | • | | • | |
| 11 | | • | | • | • |
| 12 | | • | • | | |
| 13 | | • | • | | • |
| 14 | | • | • | • | |
| 15 | | • | • | • | • |

| | | | | | |
|----|---|---|---|---|---|
| 16 | • | | | | |
| 17 | • | | | | • |
| 18 | • | | | • | |
| 19 | • | | | • | • |
| 20 | • | | • | | |
| 21 | • | | • | | • |
| 22 | • | | • | • | |
| 23 | • | | • | • | • |
| 24 | • | • | | | |
| 25 | • | • | | | • |
| 26 | • | • | | • | |
| 27 | • | • | | • | • |
| 28 | • | • | • | | |
| 29 | • | • | • | | • |
| 30 | • | • | • | • | |
| 31 | • | • | • | • | • |

Year Code :

| Year | Code | | |
|------|------|---|---|
| 2003 | | | |
| 2004 | | | • |
| 2005 | • | • | |
| 2006 | | • | • |

| Year | Code | | |
|------|------|---|---|
| 2007 | • | | |
| 2008 | • | | • |
| 2009 | • | • | |
| 2010 | • | • | • |

Absolute Maximum Ratings

| Parameter | | Symbol | Ratings | Units |
|-------------------------------------|---|------------------|----------------------------|-------|
| Supply Voltage | | | -0.3~+10.0 | V |
| LX Pin Switch Voltage | | | -0.3~V _{OUT} +0.3 | V |
| FB Pin Switch Voltage | | | -0.3~V _{OUT} +0.3 | V |
| CE Pin Switch Voltage | | | -0.3~V _{OUT} +0.3 | V |
| LX Pin Switch Current | | | 1.2 | A |
| Junction Temperature | | T _J | +150 | °C |
| Thermal Resistance | SOT-23-6 | θ _{JA} | 250 | °C/W |
| Power Dissipation | SOT-23-6 | P _D | 300 | mW |
| Operating Ambient Temperature | | T _{OPR} | -20 ~ +70 | °C |
| Storage Temperature | | T _{STG} | -55 ~ +150 | °C |
| Lead Temperature (soldering, 10sec) | | | +260 | °C |
| ESD Ratings | Human Body Model, per MIL-STD-883D-3015.7 | | 1.0 | KV |
| | Machine Model, MIL-STM5.2-1999 | | 75 | V |

Electrical Characteristics

(V_{IN}=+3.0V, T_A=25°C, unless otherwise noted.)

| Symbol | Parameter | Test Conditions | Min | Typ | Max | Unit |
|---------------------|---------------------------------------|-----------------|-----|-----|-----|------|
| V _{IN} | Input Voltage Range | | 2.5 | | 5.5 | V |
| V _{REF} | Reference Voltage | | 360 | 400 | 440 | mV |
| T _{ON} | Switch Maximum On Time | | 3.6 | 4.8 | 7.2 | µS |
| T _{OFF} | Switch Maximum Off Time | | 300 | 400 | 600 | nS |
| V _{OVP} | Overvoltage Threshold | | 18 | 19 | 20 | V |
| I _{DD2} | Switch Off Current (V _{IN}) | FB=0.5V | | 30 | 60 | µA |
| I _{OFF} | Shutdown Current (V _{IN}) | CE = 0V | | 0.1 | 1 | µA |
| | CE Input Voltage Threshold | | 0.4 | 0.7 | 1.5 | V |
| | CE Input Bias Current | | | | 1 | µA |
| | FB Input Bias Current | | | 40 | 80 | µA |
| UVLO | Under Voltage Lockout | | 2.0 | 2.2 | 2.4 | V |
| R _{DS(ON)} | Switch On Resistance | | | 0.6 | 1.0 | Ω |
| I _{Limit} | Current Limit | | 300 | 400 | 450 | mA |

Function Block Diagram

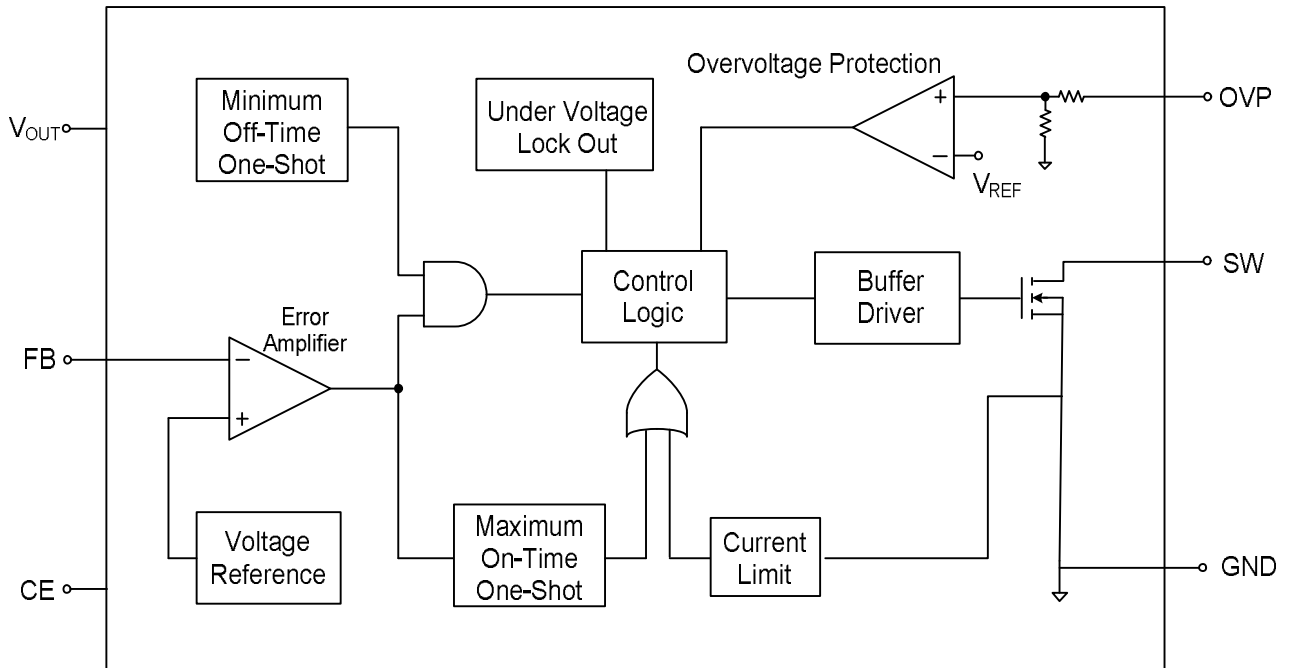

Figure 2. AP8807 Simplified Functional Block Diagram

Typical Application Circuit

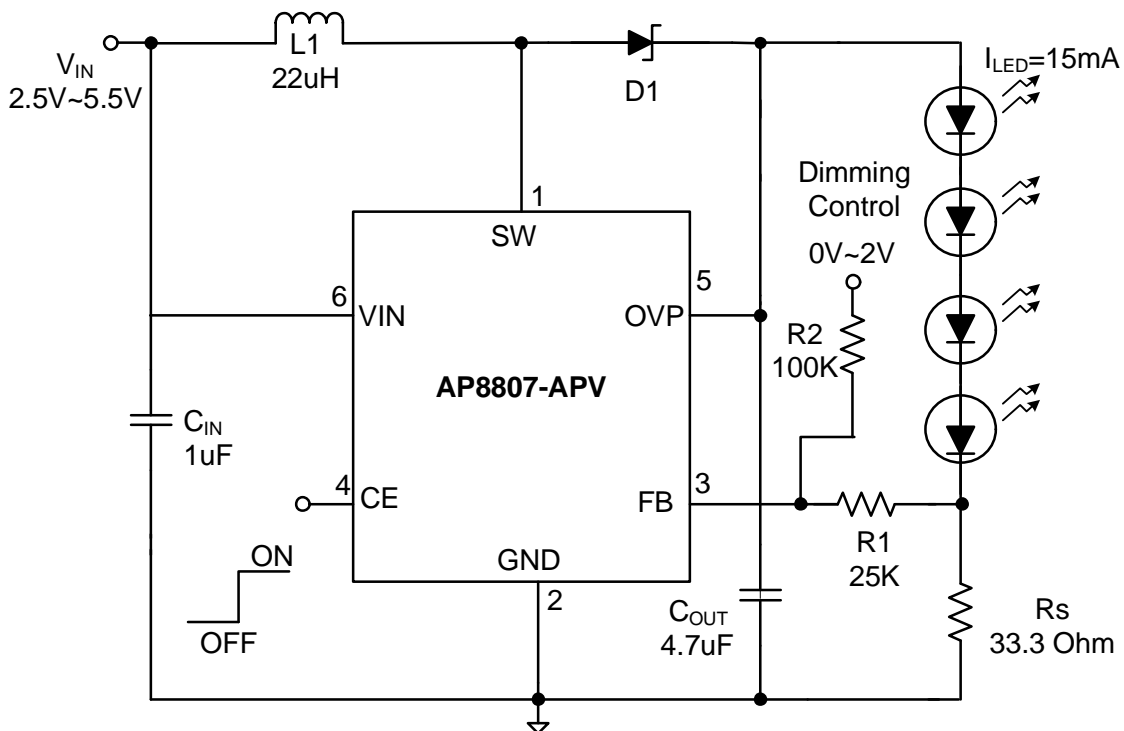

Figure 3. White LED application with DC voltage dimming control

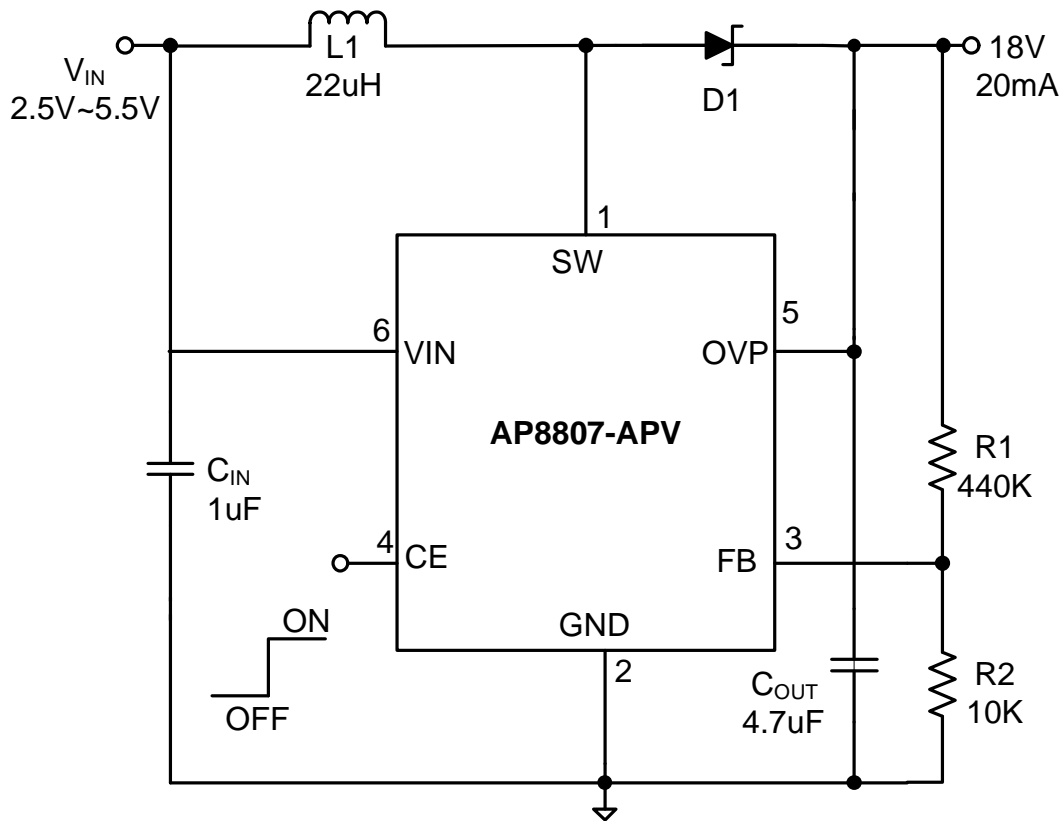

Figure 4. Typical 18V application for line drivers of LCD bias

Detail Description

The AP8807 is like a standard current-limit PFM step-up DC-DC converter, but regulates the voltage across the sense resistor R_s instead of the output voltage. This results in a constant LED current regardless the input voltage and number of LEDs connected. With integrated overvoltage protection (OVP), the AP8807 can be used as a current source with overvoltage protection to drive LEDs. The device can generate output voltage up to 18V at 20mA load with the 20V internal switch and the internal 400mA MOSFET switch. This allows up to 4 LEDs to be connected in series to the output. The low 400mV feedback reference voltage reduces power loss and improves efficiency.

Step-Up Converter

The step-up DC-DC converter operation can be understood by referring to the block diagram in Figure 4. PFM comparator monitors the output voltage via the sense resistor. When the feedback voltage is higher than the reference voltage, the MOSFET switch is turned off. As the feedback voltage is lower than reference voltage and the MOSFET switch has been off for at least a period of minimum off-time decided by the minimum off-time one-shot, the MOSFET switch is then turned on for a period of on-time decided by maximum on-time one-shot, or until the current limit signal is asserted.

During the internal MOSFET switch is turned on, current ramps up in the inductor and store energy in a magnetic field. When the MOSFET is turned off, the voltage across the inductor reverses and forces current through the diode to the output filter capacitor and load, so the energy in the inductor is transferred to output filter capacitor and the load. As the energy stored in the inductor is depleted, the current ramps down and the output diode turns off. The output filter capacitor stores the charge while the inductor current is higher than the output current, then sustains the output voltage until the next switching cycle.

Current Limit

The AP8807 utilizes cycle-by-cycle current limiting by means of protecting the output MOSFET switch from overstress and preventing the small value

inductor from saturation. Current limiting is implemented by monitoring the output MOSFET current build-up during conduction, and upon sensing an over-current conduction immediately turning off the switch for the duration of the oscillator cycle.

The current through the output MOSFET is monitored and compared against a reference signal. When the threshold is reached, a signal is sent to the PFM controller block to terminate the power switch conduction. The current limit threshold is typically set at 400mA.

Overvoltage Protection

Since AP8807 is configured as current source, the output voltage rises as the output impedance increases or output is open-circuit (e.g. fault LED). The output voltage may exceed the 20V maximum voltage rating of the internal main switch. An overvoltage protection circuit is integrated to prevent the main switch from burning. When the output voltage exceeds the OVP threshold voltage, the main switch is turned off. It remains off until the output voltage falls below the OVP threshold voltage. The step-up converter continues normal operation as long as the output voltage is under the OVP threshold.

Shutdown

The AP8807 enters shutdown to reduce quiescent current to typically 0.5 μ A when CE pin is low. For normal operation, drive CE high or connect CE to V_{OUT} . During shutdown, the reference, all feedback and control circuitry are off. The boost converter's output drops to one Schottky diode voltage drop below the input voltage and LX remains high impedance. The capacitance and load at V_{OUT} determine the rate at which V_{OUT} decays. Shutdown can be pulled as high as 6V, regardless of the voltage at V_{OUT} . The CE pin can also be used as dimming control. More details are in the dimming control section.

Undervoltage Lockout

An undervoltage lockout (UVLO) circuit prevents fault operation of the AP8807 when input voltage is under 2.2V (Typ). The device remains off as long as the input voltage is under the UVLO threshold.

APPLICATION INFORMATION

LED Current Control

The LED current is set by the sense resistor Rs. The voltage across the sense resistor is regulated to the reference voltage 400mV. In order to have accurate LED current, high precision resistors are preferred (1% is recommended). The LED current can be calculated as:

$$I_{LED} = 400mV / R_s$$

| I _{LED} (mA) | R _s (ohm) |
|-----------------------|----------------------|
| 5 | 80 |
| 10 | 40 |
| 15 | 26.6 |
| 20 | 20 |

Dimming Control

There are several types of dimming control circuit as follows:

1. Using a PWM signal to CE pin

When using a PWM signal at CE pin, the AP8807 is turned on or off by the PWM signal. The average LED current increases proportionally with the duty cycle of the PWM signal. The typical frequency range of the PWM signal is 1KHz to 10KHz. The magnitude of the PWM signal should be greater than the threshold voltage of CE voltage high.

2. Using a DC voltage

A DC voltage signal can be used as well to control the LED brightness. The dimming control method is shown in the figure below.

When the DC voltage is zero, the LED is fully turned on. As the DC voltage increases, the voltage drop on R2 increases and the voltage drop on R1 decreases. Thus the LED current decreases. The selection of R1 and R2 should make the current from the variable DC source much smaller than the LED current and much larger than the FB pin bias current.

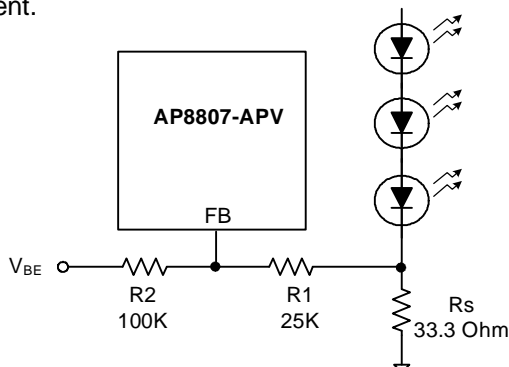

For VDC range from 0V to 2V, the selection of resistors in this figure gives dimming control of LED current from 0mA to 15mA. Following steps are used to select the resistor values:

Select the voltage V_{MAX} to turn the LEDs off. (e.g. 2.0V)

Select 0V as default to turn the LEDs fully on.

Select the maximum LED current I_{MAX} (e.g. 15mA) and 0mA as the minimum LED current.

Calculate R2 to achieve a feedback current in the range of I1 = 3μA to 10μA as the LEDs are fully turned on:

$$R2 = V_{REF} / I1 \text{ (e.g. } 0.4V / 4\mu A = 100K\Omega)$$

Calculate R1 to meet the equation:

$$R1 / (R1 + R2) = V_{REF} / V_{MAX}$$

(e.g. V_{REF}=0.4V, V_{MAX}=2.0V, R2=100KΩ, the calculated R1 is 25KΩ)

Calculate the sense voltage Vs at maximum LED current:

$$V_s = V_{REF} \times (1 + R1/R2)$$

(e.g. Vs = 0.4V x (1 + 25K/100K) = 0.5V)

Calculate the sense resistor Rs:

$$R_s = V_s / I_{MAX} \text{ (e.g. } 0.5V / 15mA = 33.3\Omega)$$

3. Using a Filtered PWM signal

The filtered PWM signal can be considered as an adjustable DC voltage. It can be used to replace the DC voltage source if adjustable analog signal is not available in the system. The circuit is shown in the figure below:

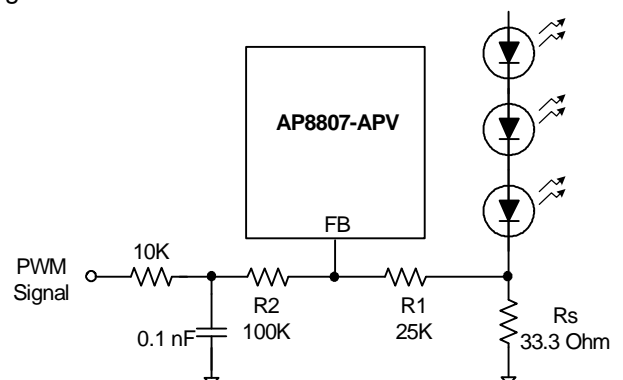

4. Using a Logic Signal

The LED current can be controlled in discrete steps with a logic signal as shown in the figure

below. When the NMOS is off, R1 set the minimum current. When the NMOS is on, R2 sets the LED current increment value.

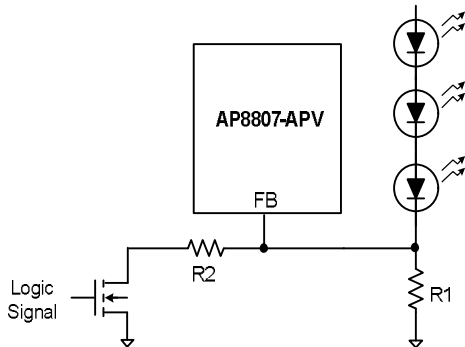

Start-Up and Inrush Current

The AP8807 has no internal soft start circuit included to achieve minimum start-up delay. All inductive step-up converters have higher inrush current during start-up. The inrush current for AP8807 is about 200mA. If soft-start is required, a recommended external circuit is shown in the below figure.

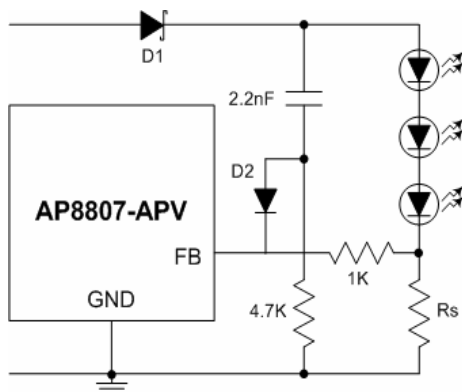

Output Voltage Selection

Referring to Fig.3, select an output voltage for AP8807-APV (400mV reference) by connecting FB to a resistive divider between the output and GND. The V_{OUT} can be set as:

$$V_{OUT} = (1+R1/R2) \times 400mV$$

Higher R1, R2 values reduce quiescent current, but give bad noise immunity. To keep stable feedback loop operation and better noise immunity, select (R1+R2) value less than 1MΩ

Inductor Selection

The AP8807 is designed to work well with a 22μH inductor in most applications. Low inductance values supply higher output current, but also increase the ripple and reduce efficiency. Higher inductor values reduce ripple and improve efficiency, but also limit output current. Choose a low DC-resistance inductor, usually less than 1Ω to minimize loss. It is necessary to choose an inductor with saturation current greater than the peak current that the inductor will encounter in the application. Saturation occurs when the inductor's magnetic flux density reaches the maximum level the core can support and inductance falls. Inductor with 500mA rating or greater would be suitable for the AP8807.

Capacitor Selection

The input capacitor stabilizes the input voltage and minimizes the peak current ripple from the source. The value of the capacitor depends on the impedance of the input source used. Small ESR (Equivalent Series Resistance) ceramic capacitor with value of 1μF to 4.7μF would be suitable.

The output capacitor is used to sustain the output voltage when the internal MOSFET is switched on and smoothing the ripple voltage. The larger the output ripple, the larger the line regulation, which means the LED current changes if the input voltage changes. Low ESR capacitor should be used to reduce output ripple voltage. Use a 4.7μF to 10μF ceramic output capacitor with about 50mΩ to 150mΩ ESR to provide stable switching and good line regulation.

Schottky Diode Selection

The diode is the largest source of loss in DC-DC converters. The most important parameters which affect the efficiency are the forward voltage drop, V_F , and the reverse recovery time. The forward voltage drop creates a loss just by having a voltage across the device while a current flowing through it. The reverse recovery time generates a loss when the diode is reverse biased, and the current appears to actually flow backwards through the diode due to the minority carriers being swept from the P-N junction. A Schottky diode with the following characteristics is recommended:

AP8807 Series

Small forward voltage, $V_F = 0.3\text{ V}$
Small reverse leakage current
Fast reverse recovery time/switching speed
Rated current larger than peak inductor current
Reverse voltage larger than output voltage

Layout Considerations

High switching frequencies make PC board layout a very important part of design. Good design minimizes excessive EMI on the feedback paths and voltage gradients in the ground plane, both of which can result in instability or regulation errors.

Connect the inductor, input filter capacitor, and output filter capacitor as close to the device as possible, and keep their traces short, direct, and wide to reduce power loss so as to improve efficiency. Connect their ground pins at a single common node in a star ground configuration, or at a full ground plane.

The output capacitor should be placed close to the output terminals to obtain better smoothing effect on the output ripple.

In addition, the ground connection for the sense resistor R_s should be tied directly to the GND pin and not shared with any other component. This ensures a clean, noise-free connection.

Precaution

When testing the AP8807 on socket with external components, keep the wiring from inductor to SW pin and the wiring from SW pin to Schottky diode as short and thick as possible to prevent the device from damage. Long and thin wires would have equivalent small inductance between SW pin and Schottky diode, which could result in unexpected high voltage and damage the SW pin.

Always connect V_{OUT} to V_{OVP} pin to protect the AP8807. Unexpected open load or incorrect circuit connections could result in high voltage at V_{OUT} and damage the SW pin

Typical Operating Characteristics

($V_{IN}=+3.0V$, Load=4 LEDs, $L=22\mu H$, $C_{IN}=1\mu F$, $C_{OUT}=4.7\mu F$, $T_A=+25^\circ C$, unless otherwise noted.)

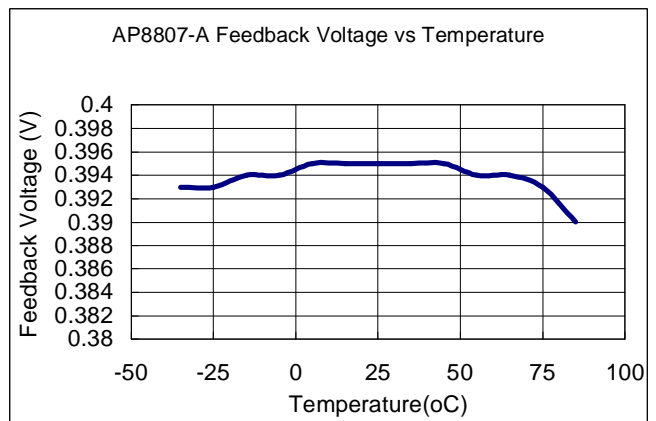
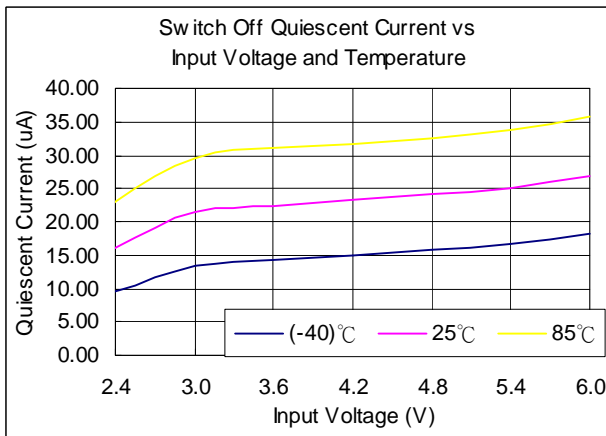
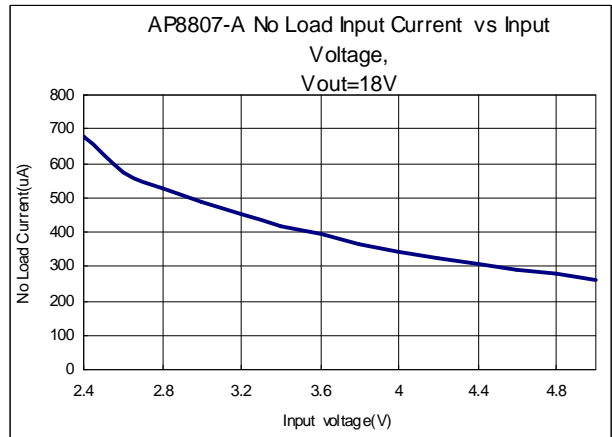
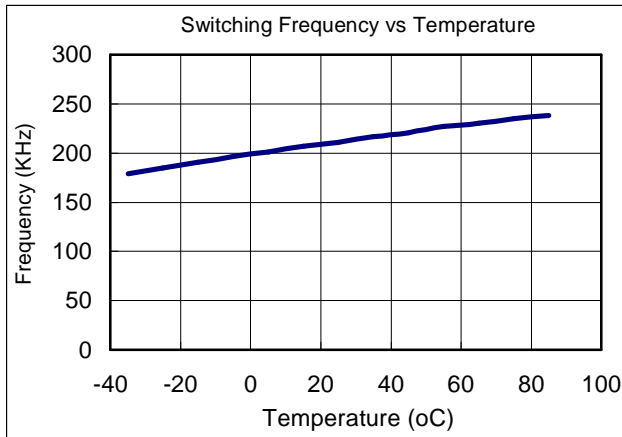
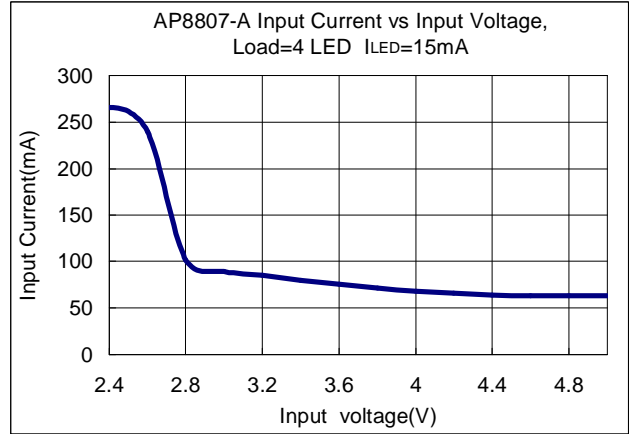
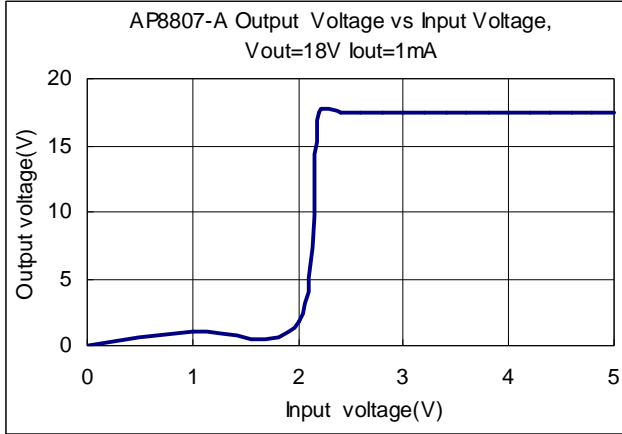

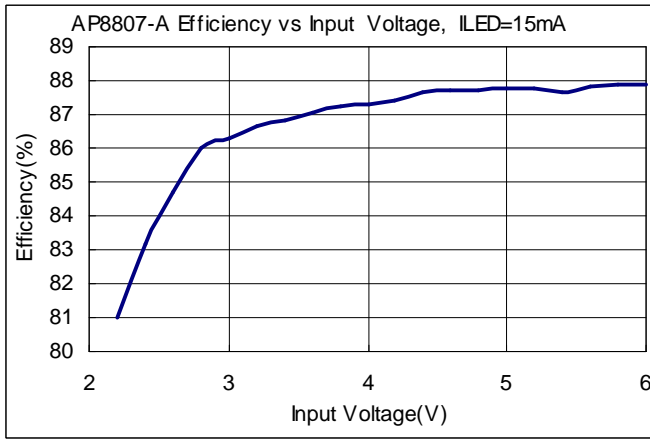
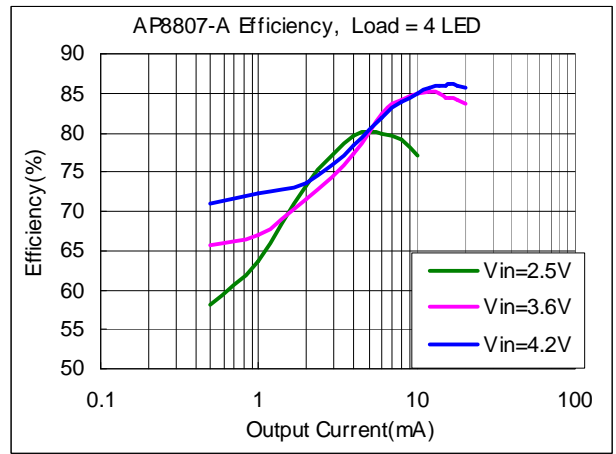
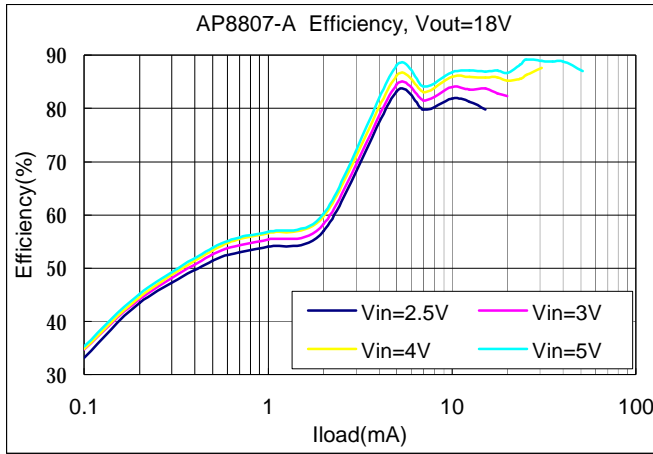

AP8807 Series

Package Outline

A) SOT-23-6

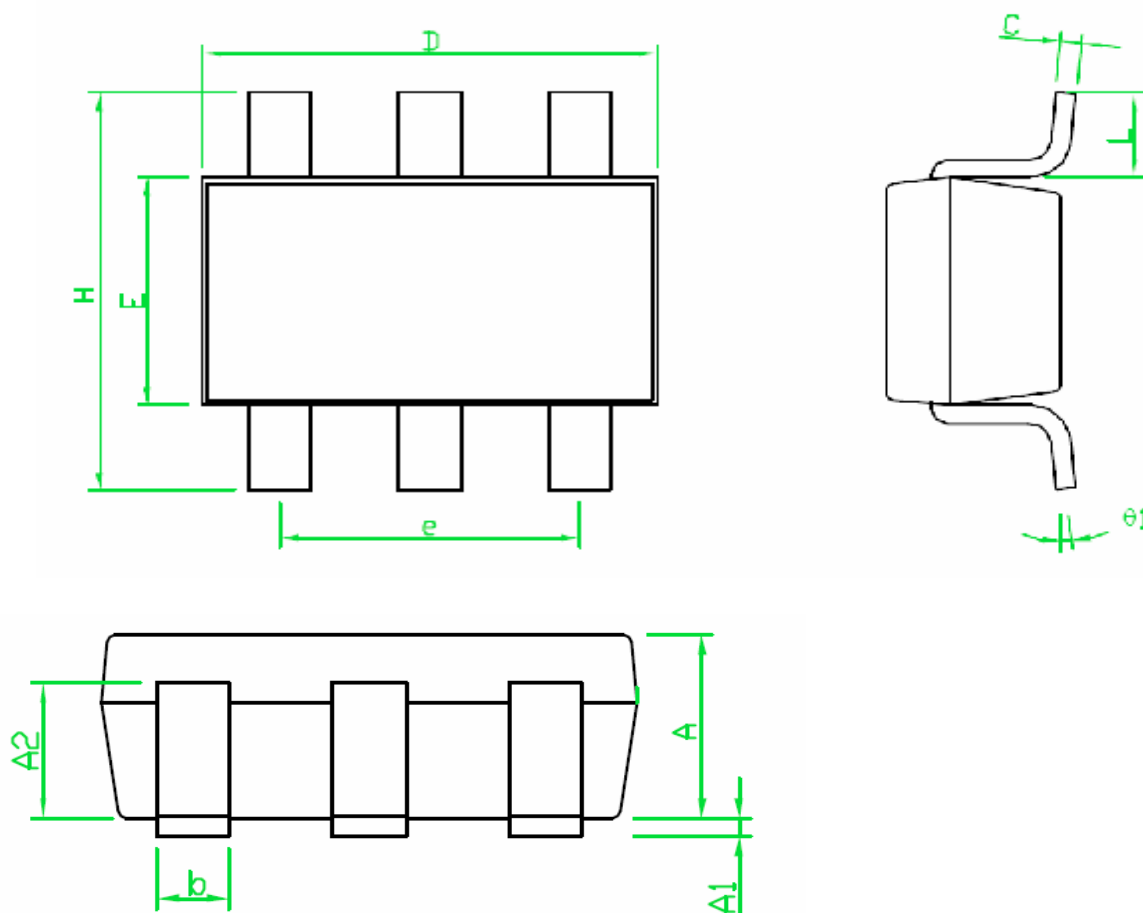

| SYMBOLS | DIMENSIONS IN MILLIMETERS | | |
|------------|---------------------------|-----------|------|
| | MIN | NOM | MAX |
| A | 1.00 | 1.10 | 1.30 |
| A1 | 0.00 | ---- | 0.10 |
| A2 | 0.70 | 0.80 | 0.90 |
| b | 0.35 | 0.40 | 0.50 |
| C | 0.10 | 0.15 | 0.25 |
| D | 2.70 | 2.90 | 3.10 |
| E | 1.40 | 1.60 | 1.80 |
| e | ---- | 1.90(TYP) | ---- |
| H | 2.60 | 2.80 | 3.00 |
| L | 0.37 | ---- | ---- |
| $\theta 1$ | 1° | 5° | 9° |
| | | | |
| | | | |

Reflow Condition (IR/Convection or VPR Reflow)

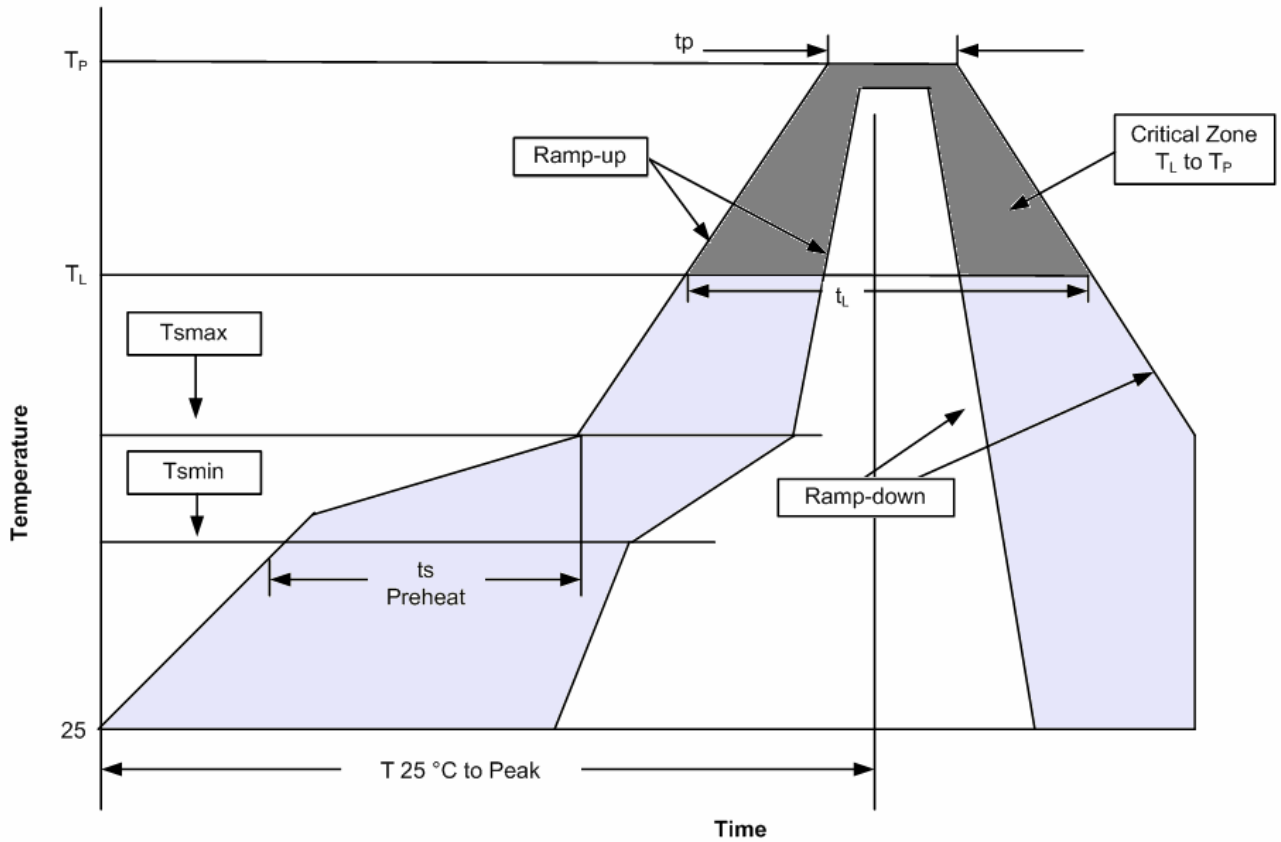

Classification Reflow Profiles

| Profile Feature | Pb-Free / Green Assembly |
|--|----------------------------------|
| Average ramp-up rate (T _L to T _P) | 3°C/second max |
| Preheat - Temperature Min (T _{min}) - Temperature Max (T _{max}) - Time (min to max) (t _s) | 150°C 200°C 60-180 seconds |
| Time maintained above: - Temperature (T _L) - Time (t _L) | 217°C 60-150 seconds |
| Peak/Classification Temperature (T _P) | See table 1 |
| Time within 5°C of actual Peak Temperature (t _p) | 20-40 seconds |
| Ramp-down Rate | 6°C/second max |
| Time 25°C to Peak Temperature | 8 minutes max |

Notes :

- 1) All temperatures refer to topside of the package.
- 2) Measured on the body surface.

Classification Reflow Profiles (Continued)

Table 1. Pb-free / Green Process – Package Classification Reflow Temperatures

| Package Thickness | Volume mm ³ <350 | Volume mm ³ 350~2000 | Volume mm ³ ≥2000 |
|-------------------|--------------------------------|------------------------------------|---------------------------------|
| <2.5 mm | 260 +0°C* | 260 +0°C* | 260 +0°C* |
| 1.6-2.5 mm | 260 +0°C* | 250 +0°C* | 245 +0°C* |
| ≥2.5 mm | 250 +0°C* | 245 +0°C* | 245 +0°C* |

Notes :

* Tolerance: The device manufacturer/supplier shall assure process compatibility up to and including the stated classification temperature (this means Peak reflow temperature +0°C. For example 260°C+0°C) at the rated MSL level.